

RB-SHERPA



INDOOR & OUTDOOR
LOGISTICS APPLICATIONS
DUE TO ITS
VERSATILITY & HIGH MOBILITY

LOGISTICS (ORDER PREPARATION DELIVERY
PICKING & TRANSPORT)

DELIVERY APPLICATIONS

AGRICULTURE

MILITARY



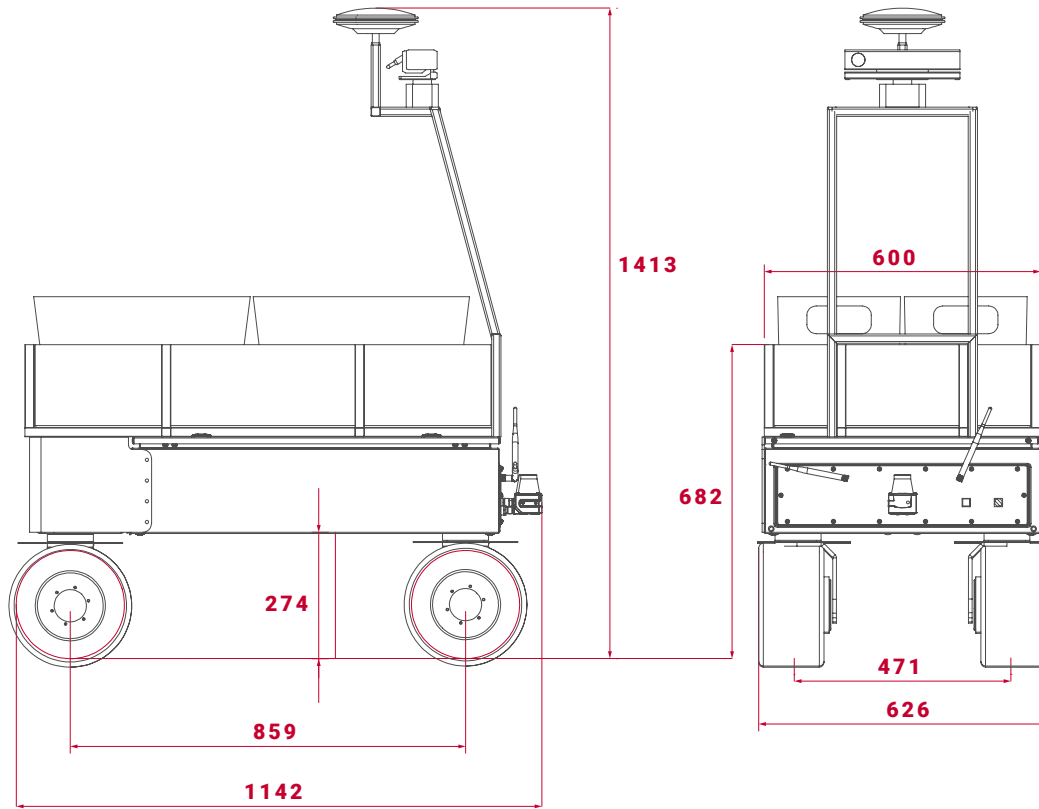

TECHNICAL SPECIFICATIONS

MECHANICAL

Dimensions	1.142 x 1.413 x 626 mm
Weight	123 Kg
Speed	3 m/s
Enclosure class	IP54 / IP65
Autonomy	10 h continuous motion
Batteries	LiFePO₄ 15Ah@48V
Traction motors	4 x 500 W
Steering motors	2/4 x 200 W
Temperature range	-10°C to +45°C
Payload	100 Kg
Max. Slope	20 %

CONTROL

Controller	Open architecture ROS Integrated PC with Linux (Intel BayTrail J1900 or similar)
Communication	WiFi 802.11n
Connectivity	External: USB, RJ42, power supplies