

RB-SHERPA



INDOOR & OUTDOOR
LOGISTICS APPLICATIONS
DUE TO ITS
VERSATILITY & HIGH MOBILITY

LOGISTICS (ORDER PREPARATION
DELIVERY PICKING & TRANSPORT)

DELIVERY APPLICATIONS

AGRICULTURE

MILITARY



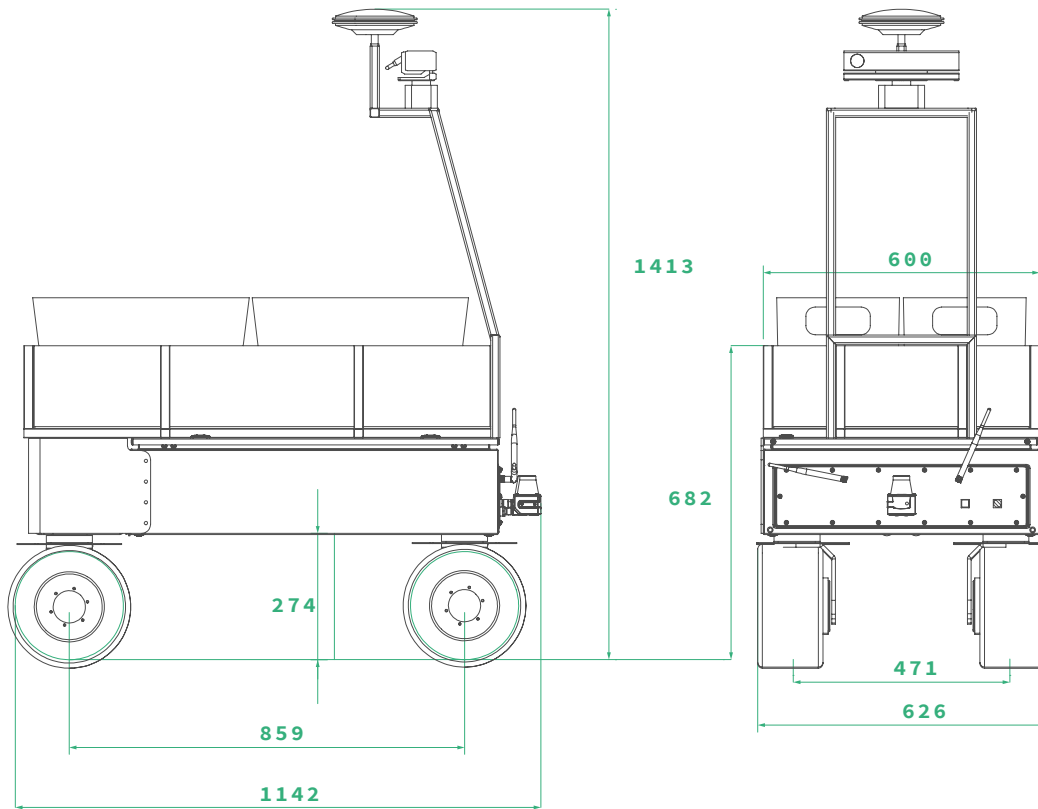

TECHNICAL SPECIFICATIONS

MECHANICAL

Dimensions **1.142 x 1.413 x 626 mm**

Weight **123 Kg**

Speed **3 m/s**

Enclosure class **IP54 / IP65**

Autonomy **10 h continuous motion**

Batteries **LiFePO₄ 15Ah@48V**

Traction motors **4 x 500 W**

Steering motors **2/4 x 200 W**

Temperature range **-10°C to +45°C**

Max step **120 mm**

Payload **100 Kg**

Max. Slope **20 %**

CONTROL

Controller **Open architecture ROS Embedded PC with Linux (Intel BayTrail J1900 or similar)**

Communication **WiFi 802.11n**

Connectivity **External: USB, RJ42, power supplies**